



PENKO Engineering BV

The Leading Experts In Weighing & Dosing

500kg-5000kg **ACB**

FEATURES

- Capacities: 500 kg, 1T, 2T, and 5T
- Low profile, stainless steel construction
- Hermetically sealed, IP66 and IP68
- Certified to OIML R60, 6000d
- 1000 Ohm bridge impedance
- Current calibration output (SC) ensures easy and accurate connection of multiple load cells
- Integral mounting step
- **Optional**
 - ATEX versions are available for use in potentially explosive atmospheres, caused by gas or dust



APPLICATIONS

- Platform scales
- Belt scales
- Overhead track scales
- Silo hopper weighing

DESCRIPTION

The ACB is a high performance stainless steel beam type load cell. An integral mounting step removes the need for spacer plates and ensures optimum "bolt down" conditions.

This product is suitable for small and medium platform scales, hybrid scales, pallet weighers, and process weighing.

The fully welded construction and the cable entry ensure that this product can be used successfully in harsh environments found in the food, chemical, and allied process industries.

OUTLINE DIMENSIONS in millimeters

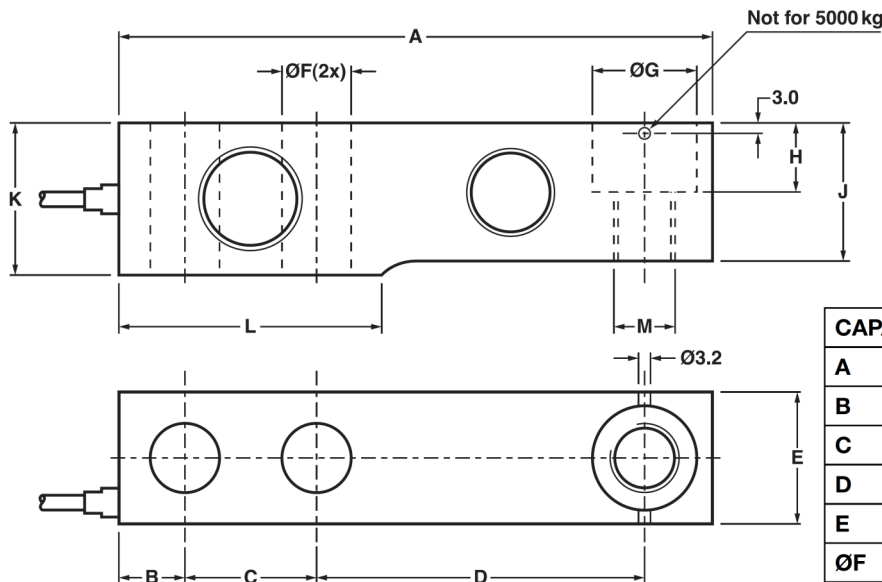

Cable specifications:

Cable length: 3m for 500 kg, 1T
6m for 2T, 5T

Excitation + Green
Excitation - Black
Sense + Yellow
Sense - Blue
Output + White
Output - Red
Shield Transparent

CAPACITY	500 kg	1000 kg	2000 kg	5000 kg
A	130.0	130.0	130.0	172.0
B	15.5	15.5	15.5	19.1
C	25.4	25.4	25.4	38.1
D	76.2	76.2	76.2	95.3
E	31.8	31.8	31.8	38.0
ØF	13.0	13.0	13.0	20.5
ØG	20.5	20.5	20.5	30.2
H	14.2	14.2	14.2	20.0
J	26.0	27.95	31.95	40.0
K	31.8	31.8	35.8	44.0
L	57.1	57.1	57.1	76.2
M	M12	M12	M12	M20

Load cell ACB: 500kg-5000kg Technical Data

SPECIFICATIONS				
PARAMETER	VALUE			UNIT
Standard capacities (E_{max})	500, 1000, 2000, 5000			kg
Accuracy class according to OIML R-60	Non-Approved	C3	C6 ⁽¹⁾	
Maximum no. of verification intervals (n)		3000	6000	
Minimum verification interval, ($V_{min} E_{max}/Y$)		$E_{max}/6000$	$E_{max}/12,000$	
Minimum verification interval, Type MR		$E_{max}/15,000$	$E_{max}/20,000$	
Rated output (=S)	2			mV/V
Tolerance on rated output	0.02			±mV/V
Zero balance	1.0			±% FSO
Combined error	0.0500	0.0230	0.0120	±% FSO
Non-repeatability	0.070	0.035	0.018	±% FSO
Minimum dead load output return	0.0500	0.017	0.008	±% of applied load
Creep error (30 minutes)	0.0600	0.0245	0.012	±% of applied load
Temperature effect on minimum dead load	0.0250	0.0117	0.0058	±% FSO/5°C
Temperature effect on sensitivity	0.0250	0.0088	0.0045	±% applied load/5°C
Maximum safe over load	150			% E_{max}
Ultimate over load	300			% E_{max}
Maximum safe side load	100			% E_{max}
Deflection at E_{max}	0.20, 0.20, 0.22, 0.31			mm
Excitation voltage	5 to 12			V
Maximum excitation voltage	15			V
Input resistance	1000±50			Ω
Output resistance	1000±10			Ω
Insulation resistance	≥5000			MΩ
Compensated temperature range	-10 to +40			°C
Operating temperature range	-40 to +80			°C
Storage temperature range	-40 to +90			°C
Element material (DIN)	Stainless steel 1.4542			
Sealing (DIN 40.050 / EN60.529)	IP66 and IP68			
SC-Version (current calibration)	Standard			
Recommended torque on fixation bolts	150			N*m

⁽¹⁾ 500 kg is approved to C3 only

FSO—Full Scale Output

SC-version: The rated output and the output resistance are balanced in such a way, that the output current is calibrated to within 0.05% of a reference value. This allows easy parallel connection of the load cells.

All specifications subject to change without notice.

