

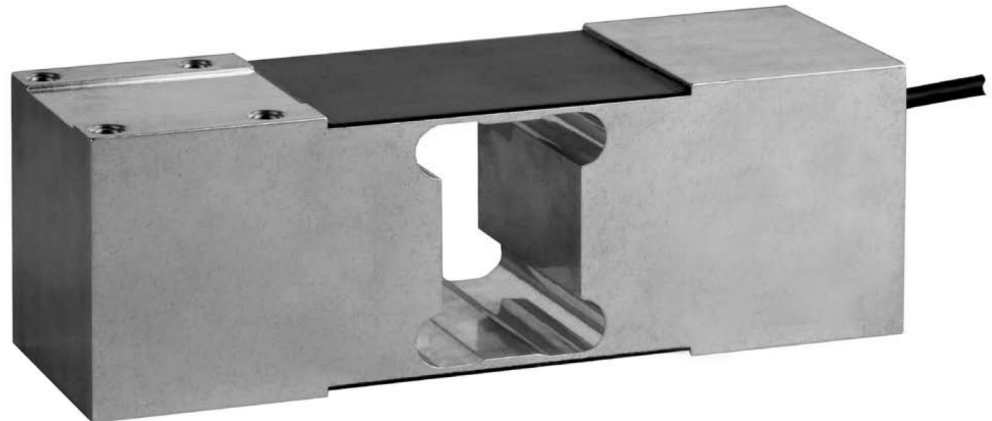

# PENKO Engineering BV

The Leading Experts In Weighing & Dosing

30kg-750kg **PC60**



## Product Description

The type PC60 is an aluminium single point load cell with an improved potting.

## Application

- Bench and floor scales, conveyor scales and medical scales

## Key Features

- Wide range of capacities from 30 kg to 750 kg
- Aluminium construction
- Environmental Protection IP67
- Maximum platform size up to 600 x 600 mm

## Approvals

- OIML approval to C3 (Y = 7 500)
- ATEX hazardous area approval for Zone 0, 1, 2, 20, 21 and 22
- FM hazardous area approval

## Option

- Y = 15 000 for C3

## Packed Weight

- 2.0 kg

## Available Accessories

- Compatible range of electronics

## Wiring

- The load cell is provided with a shielded, 6 conductor cable (AWG 26). Cable jacket polyurethane
- Cable length: 3 m
- Cable diameter: 5.8 mm
- The shield is connected to the load cell body

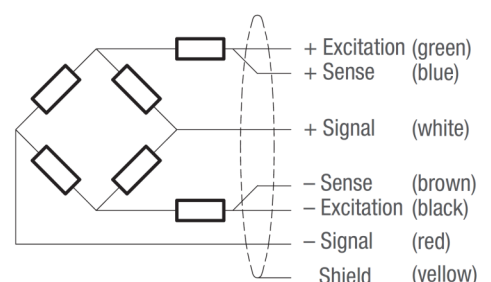

Specifications			30 / 50 / 100 / 200 / 300 / 500 / 750	
Maximum capacity	(E <sub>max</sub> )	kg	30 / 50 / 100 / 200 / 300 / 500 / 750	
Accuracy class according to OIML R60			(GP)	C3
Maximum number of verification intervals	(n <sub>max</sub> )		n.a.	3 000
Minimum load cell verification interval	(v <sub>min</sub> )		n.a.	E <sub>max</sub> / 7 500
Temperature effect on minimum dead load output	(TC <sub>0</sub> )	%*RO/10°C	≤ ± 0.0400	≤ ± 0.0187
Temperature effect on sensitivity	(TC <sub>RO</sub> )	%*RO/10°C	≤ ± 0.0200	≤ ± 0.0100
Combined error		%*RO	≤ ± 0.0500	≤ ± 0.0200
Non-linearity		%*RO	≤ ± 0.0400	≤ ± 0.0166
Hysteresis		%*RO	≤ ± 0.0400	≤ ± 0.0166
Creep error (30 minutes) / DR		%*RO	≤ ± 0.0600	≤ ± 0.0166
Option	Min. load cell verification interval	(v <sub>min opt</sub> )	n.a.	E <sub>max</sub> / 15 000
	Temp. effect on min. dead load output	(TC <sub>0 opt</sub> )	n.a.	≤ ± 0.0093
Rated Output	(RO)	mV/V	2 ± 10%	
Zero balance		%*RO	≤ ± 5	
Excitation voltage		V	5...15	
Input resistance	(R <sub>LC</sub> )	Ω	413 ± 20	
Output resistance	(R <sub>out</sub> )	Ω	350 ± 25	
Insulation resistance (100 V DC)		MΩ	≥ 5 000	
Safe load limit	(E <sub>lim</sub> )	%*E <sub>max</sub>	150	
Ultimate load		%*E <sub>max</sub>	300	
Safe side load		%*E <sub>max</sub>	100	
Maximum platform size; loading acc. to OIML R76		mm	600 x 600	
Maximum off centre distance at maximum capacity		mm	200	
Compensated temperature range		°C	-10...+40	
Operating temperature range		°C	-20...+65 (ATEX -20...+60)	
Load cell material			aluminium	
Sealing			potted	
Protection according EN 60 529			IP67	

The limits for Non-Linearity, Hysteresis, and TC<sub>RO</sub> are typical values.  
 The sum of Non-linearity, Hysteresis and TC<sub>RO</sub> meets the requirements according to OIML R60 with p<sub>LC</sub>=0.7.

## Dimensions (in mm)

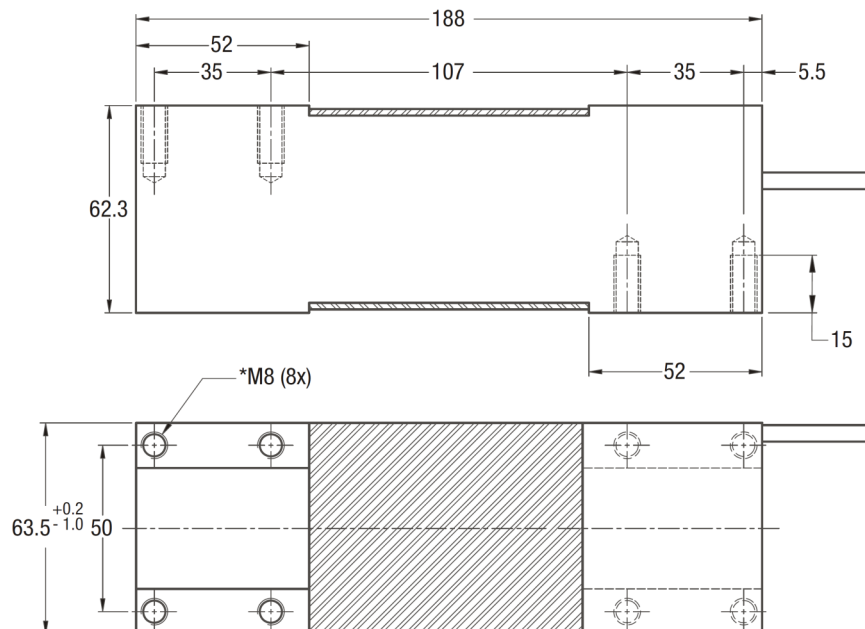

Mounting bolts M8 8.8; torque 25 Nm. Torque value assumes oiled threads.  
 \* Unified thread 5/16-18 UNC is available.

