



# PENKO Engineering BV

The Leading Experts In Weighing & Dosing

1500kg-5000kg

# 619

## S-Type Alloy Steel Load Cell

### FEATURES

- Capacities 1500–5000 kg
- Alloy steel construction
- Sealing: welded to IP67
- S-Type design for use in tension and compression
- 6 Wire cable (sense circuit)

### APPLICATIONS

- Hopper (tank weighing)
- Hybrid scales
- Belt weighing
- Lever arm conversions
- Material testing machines
- Vibrations filling equipment
- Dynamometers

### DESCRIPTION

Model 619 is a low cost tension-compression load cell made from nickel plated alloy steel and has bonded covers for additional protection. It is suitable for use in a wide range of weighing, process weighing, force measurement and industrial process control applications.

Protected to meet IP67 requirements, the construction of the 619 load cell allows its use in most industrial process applications.



For IP68 requirements, select the fully-welded stainless steel Model 620, which shares the same dimensions as Model 619.

The additional sense wires compensate for changes in lead resistance due to temperature change and/or cable extension. Complete compensation of changes in lead resistance is achieved by feeding this voltage into appropriate electronics.

### OUTLINE DIMENSIONS in millimeters

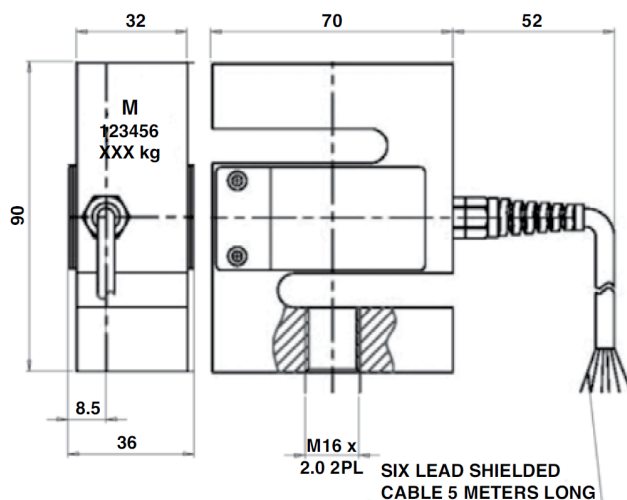

1500, 2000 kg cell outline

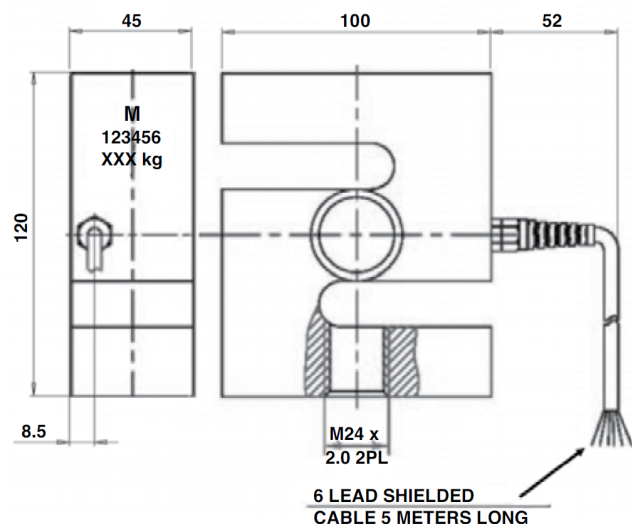

3000, 5000 kg cell outline

# Load cell 619: 1500kg-5000kg Technical Data

SPECIFICATIONS			
PARAMETER	VALUE		UNIT
Rated capacity—R.C. (E <sub>max</sub> )	1500, 2000, 3000, 5000		kg
Accuracy class	E	G	
Maximum no. of intervals (n)	1000	3000	
Rated output—R.O.	2.0		mV/V
Rated output tolerance	0.002		±mV/V
Zero balance	0.04		±mV/V
Zero return, 30 min.	0.050	0.0170	±% of applied load
Total error	0.050	0.020	±% of rated output
Temperature effect on zero	0.030	0.0040	±% of rated output/°C
Temperature effect on output	0.0030	0.0012	±% of applied load/°C
Temperature range, compensated	-10 to +40		°C
Temperature range, safe	-20 to +70		°C
Maximum safe central overload	150		% of R.C.
Ultimate central overload	300		% of R.C.
Excitation, recommended	10		VDC or VAC RMS
Excitation, maximum	15		VDC or VAC RMS
Input impedance	380±20		Ω
Output impedance	350±3		Ω
Insulation resistance	>2000		MΩ
Cable length	5.0		m
Cable type	6-wire, braided, PVC, dual floating screen		Standard
Construction	Nickel-plated alloy tool steel		
Environmental protection	IP67		

All specifications are subject to change without notice.

## Wiring Schematic Diagram

